

# INTERNATIONAL STANDARD

# ISO 15072

First edition  
1999-12-15

---

---

## Hexagon bolts with flange with metric fine pitch thread — Small series — Product grade A

*Vis à tête hexagonale à embase cylindro-tronconique, à filetage métrique à  
pas fin — Série étroite — Grade A*



Reference number  
ISO 15072:1999(E)

© ISO 1999

#### PDF disclaimer

This PDF file may contain embedded typefaces. In accordance with Adobe's licensing policy, this file may be printed or viewed but shall not be edited unless the typefaces which are embedded are licensed to and installed on the computer performing the editing. In downloading this file, parties accept therein the responsibility of not infringing Adobe's licensing policy. The ISO Central Secretariat accepts no liability in this area.

Adobe is a trademark of Adobe Systems Incorporated.

Details of the software products used to create this PDF file can be found in the General Info relative to the file; the PDF-creation parameters were optimized for printing. Every care has been taken to ensure that the file is suitable for use by ISO member bodies. In the unlikely event that a problem relating to it is found, please inform the Central Secretariat at the address given below.

© ISO 1999

All rights reserved. Unless otherwise specified, no part of this publication may be reproduced or utilized in any form or by any means, electronic or mechanical, including photocopying and microfilm, without permission in writing from either ISO at the address below or ISO's member body in the country of the requester.

ISO copyright office  
Case postale 56 • CH-1211 Geneva 20  
Tel. + 41 22 749 01 11  
Fax + 41 22 734 10 79  
E-mail [copyright@iso.ch](mailto:copyright@iso.ch)  
Web [www.iso.ch](http://www.iso.ch)

Printed in Switzerland

## Foreword

ISO (the International Organization for Standardization) is a worldwide federation of national standards bodies (ISO member bodies). The work of preparing International Standards is normally carried out through ISO technical committees. Each member body interested in a subject for which a technical committee has been established has the right to be represented on that committee. International organizations, governmental and non-governmental, in liaison with ISO, also take part in the work. ISO collaborates closely with the International Electrotechnical Commission (IEC) on all matters of electrotechnical standardization.

International Standards are drafted in accordance with the rules given in the ISO/IEC Directives, Part 3.

Draft International Standards adopted by the technical committees are circulated to the member bodies for voting. Publication as an International Standard requires approval by at least 75 % of the member bodies casting a vote.

Attention is drawn to the possibility that some of the elements of this International Standard may be the subject of patent rights. ISO shall not be held responsible for identifying any or all such patent rights.

International Standard ISO 15072 was prepared by Technical Committee ISO/TC 2, *Fasteners*.

Annex A forms a normative part of this International Standard.

This page intentionally left blank

# Hexagon bolts with flange with metric fine pitch thread — Small series — Product grade A

## 1 Scope

This International Standard specifies the characteristics of hexagon bolts with flange with metric fine pitch thread, small series, with product grade A, with nominal thread diameters 8 mm up to and including 16 mm and property classes 8.8, 9.8, 10.9, 12.9 and A2-70.

If, in special cases, specifications other than those listed in this International Standard are required, they should be selected from existing International Standards, for example ISO 261, ISO 888, ISO 898-1, ISO 965-2, ISO 3506-1.

## 2 Normative references

The following normative documents contain provisions which, through reference in this text, constitute provisions of this International Standard. For dated references, subsequent amendments to, or revisions of, any of these publications do not apply. However, parties to agreements based on this International Standard are encouraged to investigate the possibility of applying the most recent editions of the normative documents indicated below. For undated references, the latest edition of the normative document referred to applies. Members of ISO and IEC maintain registers of currently valid International Standards.

ISO 225:1983, *Fasteners — Bolts, screws, studs and nuts — Symbols and designations of dimensions.*

ISO 261:1998, *ISO general-purpose metric screw threads — General plan.*

ISO 898-1:1999, *Mechanical properties of fasteners made of carbon steel and alloy steel — Part 1: Bolts, screws and studs.*

ISO 965-2:1998, *ISO general purpose metric screw threads — Tolerances — Part 2: Limits of sizes for general purpose external and internal screw threads — Medium quality.*

ISO 3269:—<sup>1)</sup>, *Fasteners — Acceptance inspection.*

ISO 3506-1:1997, *Mechanical properties of corrosion-resistant stainless-steel fasteners — Part 1: Bolts, screws and studs.*

ISO 4042:1999, *Fasteners — Electroplated coatings.*

ISO 4753:1999, *Fasteners — Ends of parts with external metric ISO screw thread.*

ISO 4759-1:—<sup>2)</sup>, *Tolerances for fasteners — Part 1: Bolts, screws, studs and nuts — Product grades A, B and C.*

ISO 6157-3:1988, *Fasteners — Surface discontinuities — Part 3: Bolts, screws and studs for special requirements.*

ISO 8992:1986, *Fasteners — General requirements for bolts, screws, studs and nuts.*

---

1) To be published. (Revision of ISO 3269:1988)

2) To be published. (Revision of ISO 4759-1:1978)

### 3 Dimensions

See Figures 1 to 4 and Table 1.

Symbols and designations of dimensions are specified in ISO 225.

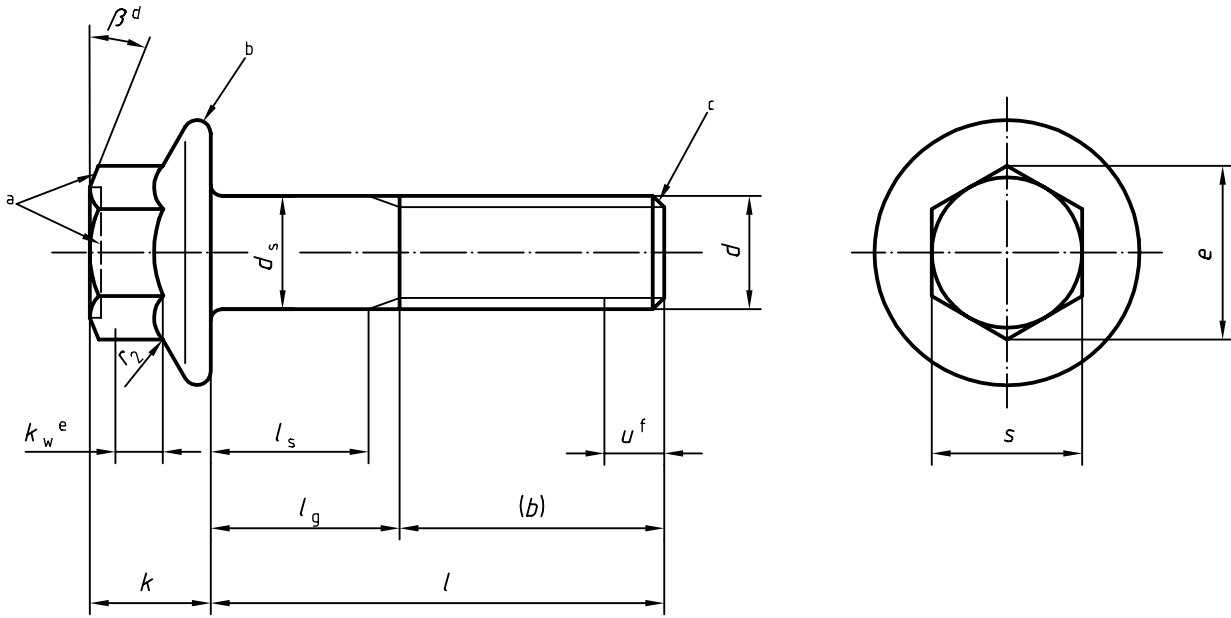

- a The top of the head shall be either full form or indented at the manufacturer's discretion and shall be either chamfered or rounded. The minimum diameter of the chamfer circle or start of rounding shall be equal to the maximum width across flats minus 15 %. If the top of the head is indented, the periphery may be rounded.
- b Edge contour optional.
- c Chamfered end (see ISO 4753).
- d  $\beta = 15^\circ$  to  $30^\circ$
- e  $k_w$  is the wrenching height; see the note to Table 1.
- f Incomplete thread  $u \leq 2 P$

**Figure 1 — Hexagon bolt with flange — Full shank (standard type)**

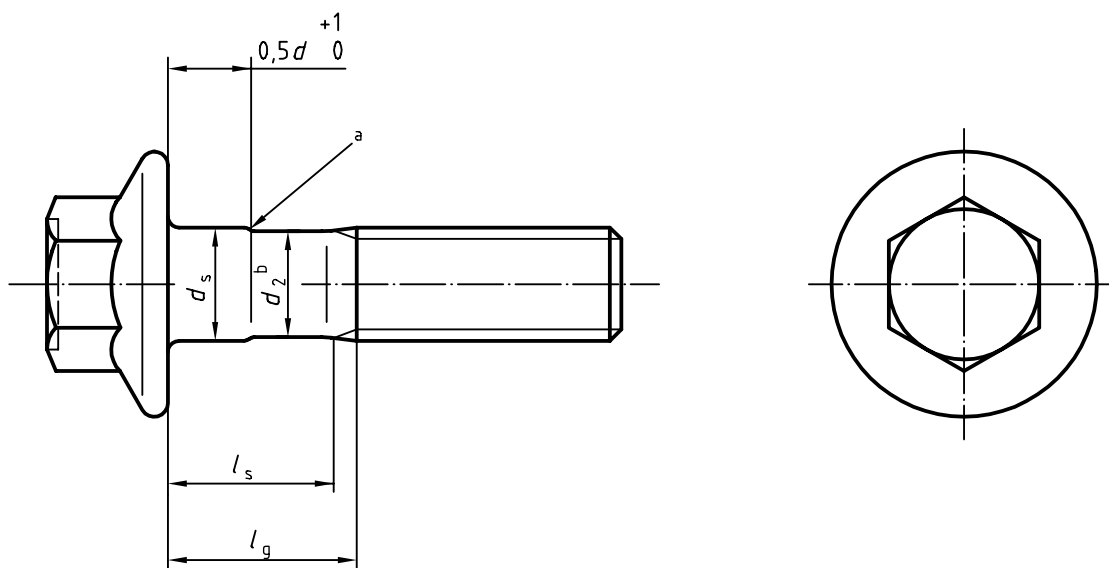

NOTE For other dimensions, see Figure 1.

- a Rounded, chamfered or conical.
- b  $d_2$  is approximately equal to the pitch diameter (rolling diameter).

Figure 2 — Hexagon bolt with flange — Reduced shank, type R (upon request)

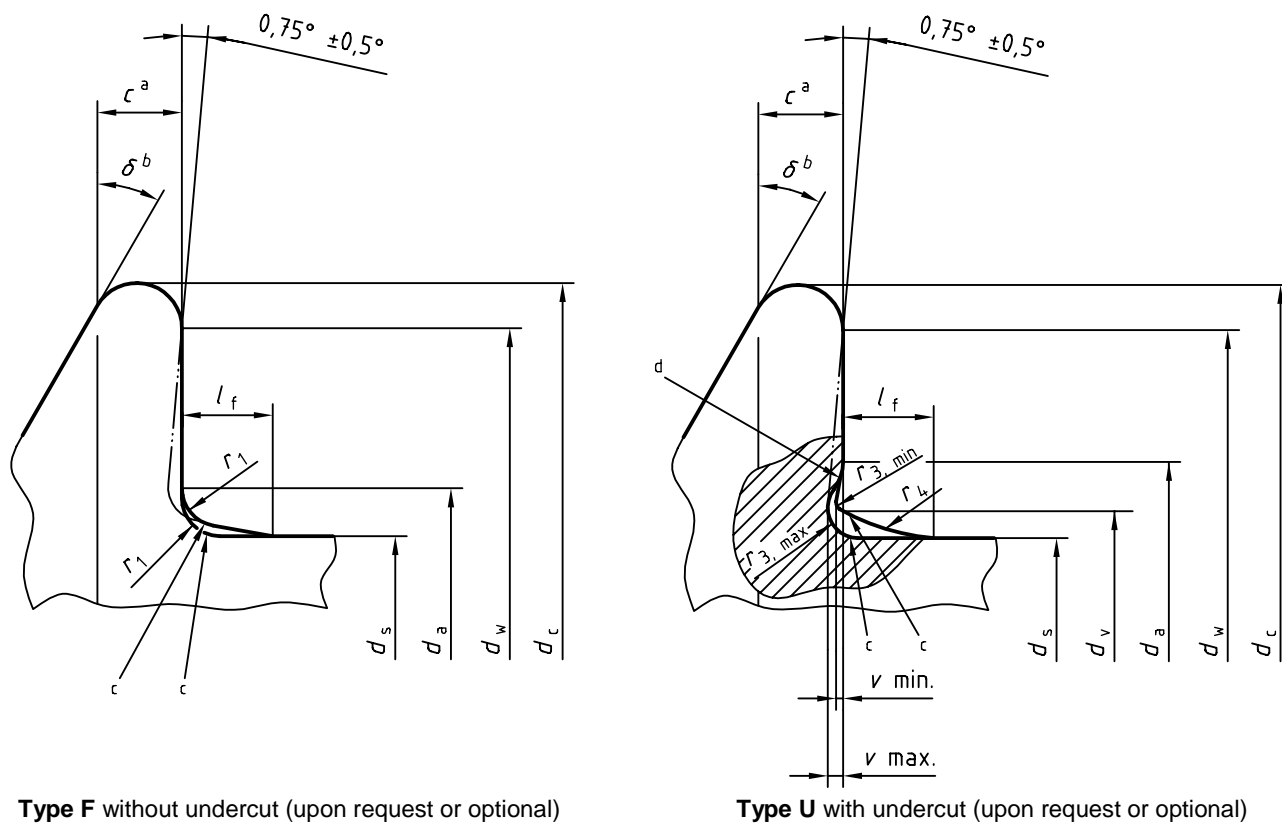

Type F without undercut (upon request or optional)

Type U with undercut (upon request or optional)

- a  $c$  is measured at  $d_w, \min$ .
- b  $\delta = 15^\circ$  to  $25^\circ$
- c Maximum and minimum underhead fillet.
- d Junction of fillet with bearing surface to be a smooth blend.

Figure 3 — Hexagon bolt with flange — Underhead configuration (bearing area)

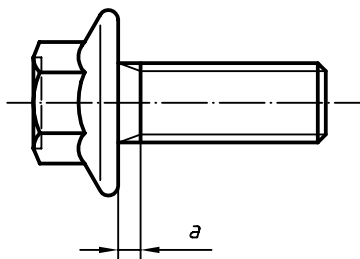

Figure 4 — Hexagon bolt with flange threaded to the head

Table 1 — Dimensions

Dimensions in millimetres

Thread ( $d \times P^a$ )		M8 x 1	M10 x 1 M10 x 1,25	M12 x 1,25 M12 x 1,5	(M14 x 1,5) <sup>b</sup>	M16 x 1,5
$a$	max.	3	3	4,5	4,5	4,5
	min.	1	1	1,5	1,5	1,5
$b$ ref.	$c$	22	26	30	34	38
	$d$	28	32	36	40	44
	$e$	—	—	—	—	57
$c$	min.	1,2	1,5	1,8	2,1	2,4
$d_a$ Types $\frac{F}{U}$	max.	9,2	11,2	13,7	15,7	17,7
		10	12,5	15,2	17,7	20,5
$d_C$	max.	17	20,8	24,7	28,6	32,8
$d_s$	max.	8,00	10,00	12,00	14,00	16,00
	min.	7,78	9,78	11,73	13,73	15,73
$d_v$	max.	8,8	10,8	12,8	14,8	17,2
$d_w$	min.	14,9	18,7	22,5	26,4	30,6
$e$	min.	10,95	14,26	16,50	19,86	23,15
$k$	max.	8,5	9,7	12,1	12,9	15,2
$k_w$	min.	3,8	4,3	5,4	5,6	6,8
$l_f$	max.	2,1	2,1	2,1	2,1	3,2
$r_1$	min.	0,4	0,4	0,6	0,6	0,6
$r_2^f$	max.	0,5	0,6	0,7	0,9	1
$r_3$	max.	0,36	0,45	0,54	0,63	0,72
	min.	0,16	0,20	0,24	0,28	0,32
$r_4$	ref.	5,7	5,7	5,7	5,7	8,8
$s$	max.	10,00	13,00	15,00	18,00	21,00
	min.	9,78	12,73	14,73	17,73	20,67
$v$	max.	0,25	0,30	0,35	0,45	0,50
	min.	0,10	0,15	0,15	0,20	0,25



Table 1 (continued)

Dimensions in millimetres

Thread ( $d \times P$ <sup>a</sup> ) $l_{g,h}$			M8 x 1		M10 x 1 M10 x 1,25		M12 x 1,25 M12 x 1,5		(M14 x 1,5) <sup>b</sup>		M16 x 1,5	
nom.	min.	max.	$l_s$ and $l_{g,i,j}$									
			$l_s$ min.	$l_g$ max.	$l_s$ min.	$l_g$ max.	$l_s$ min.	$l_g$ max.	$l_s$ min.	$l_g$ max.	$l_s$ min.	$l_g$ max.
16	15,65	16,35	—	—								
20	19,58	20,42	—	—	—	—						
25	24,58	25,42	—	—	—	—	—	—				
30	29,58	30,42	—	—	—	—	—	—	—	—		
35	34,5	35,5	6,75	13	—	—	—	—	—	—	—	—
40	39,5	40,5	11,75	18	6,5	14	—	—	—	—	—	—
45	44,5	45,5	16,75	23	11,5	19	6,25	15	—	—	—	—
50	49,5	50,5	21,75	28	16,5	24	11,25	20	6	16	—	—
55	54,4	55,6	26,75	33	21,5	29	16,25	25	11	21	7	17
60	59,4	60,6	31,75	38	26,5	34	21,25	30	16	26	12	22
65	64,4	65,6	36,75	43	31,5	39	26,25	35	21	31	17	27
70	69,4	70,6	41,75	48	36,5	44	31,25	40	26	36	22	32
80	79,4	80,6	51,75	58	46,5	54	41,25	50	36	46	32	42
90	89,3	90,7			56,5	64	51,25	60	46	56	42	52
100	99,3	100,7			66,5	74	61,25	70	56	66	52	62
110	109,3	110,7					71,25	80	66	76	62	72
120	119,3	120,7					81,25	90	76	86	72	82
130	129,2	130,8							80	90	76	86
140	139,2	140,8							90	100	86	96
150	149,2	150,8									96	106
160	159,2	160,8									106	116

NOTE If the product passes the gauging in annex A, the requirements for dimensions  $c$ ,  $e$  and  $k_w$  are satisfied.

- a  $P$  is the pitch of the thread.
- b The size in parentheses should be avoided if possible.
- c For lengths  $l_{nom} \leq 125$  mm.
- d For lengths  $125 \text{ mm} < l_{nom} \leq 200$  mm.
- e For lengths  $l_{nom} > 200$  mm.
- f Radius  $r_2$  applies both at the corners and at the flats of the hexagon.
- g Screws with lengths shown above the thick stepped line are threaded to the head.
- h Reduced shank type (type R) only below the dashed stepped line.
- i  $l_g$  is the minimum grip length.
- j  $l_{g, \max} = l_{nom} - b$   
 $l_{s, \min} = l_{g, \max} - 5 P$  ( $P$  is the pitch of the coarse thread, specified in ISO 261).

## 4 Requirements and reference International Standards

See Table 2.

**Table 2 — Requirements and reference International Standards**

Material		Steel	Stainless steel
<b>General requirements</b>	International Standard	ISO 8992	
	Tolerance	6 g	
<b>Thread</b>	International Standards	ISO 261, ISO 965-2	
	Property class	8.8, 9.8, 10.9, 12.9	A2-70
<b>Mechanical properties</b>	International Standards	ISO 898-1	ISO 3506-1
	Product grade	A	
<b>Tolerances</b>	International Standard	ISO 4759-1	
	<b>Finish</b>	Black oxide (thermic or chemical) Requirements for electroplating are covered in ISO 4042. If different electroplating requirements are desired or if requirements are needed for other finishes, they should be negotiated between customer and supplier. Limits for surface discontinuities are covered in ISO 6157-3.	Plain
<b>Acceptability</b>		For acceptance procedure, see ISO 3269.	

## 5 Designation

EXAMPLE 1 A hexagon bolt with flange, small series, product grade A, with metric fine pitch thread  $M12 \times 1,25$ , nominal length  $l = 80$  mm, type F or U at the option of the manufacturer, and property class 8.8 is designated as follows:

**Hexagon bolt with flange ISO 15072 - M12 × 1,25 × 80 - 8.8**

EXAMPLE 2 A hexagon bolt with flange, small series, product grade A, with metric fine pitch thread  $M12 \times 1,25$ , nominal length  $l = 80$  mm, type F, and property class 8.8 is designated as follows:

**Hexagon bolt with flange ISO 15072 - M12 × 1,25 × 80 - F - 8.8**

EXAMPLE 3 If, in special cases, a hexagon bolt with flange with reduced shank is required, the letter R shall be included in the designation:

**Hexagon bolt with flange ISO 15072 - M12 × 1,25 × 80 - R - 8.8**

## Annex A (normative)

### Gauging of hexagon flange heads

#### A.1 Recommended method for gauging of hexagon (see Figure A.1 and Table A.1)

The head shall be gauged using two ring gauges, A and B, to demonstrate the coincidental acceptability of hexagon height, wrenching height, corner fill and width across corners. Gauge A shall be placed over the hexagon and shall seat on the flange. Gauge B shall be placed on the top of the head normal to the bolt axis. The two gauges shall not be in contact.

#### A.2 Recommended method for gauging of flange thickness (see Figure A.1 and Table A.1)

Gauge C is a flat feeler or ring gauge. It is used to prove that the flange thickness at the junction of the gauge with the hexagon portion is equal to or greater than specified values. The acceptance criterion is that gauge C will fit under gauge A without contact when the bolt head is seated on a flat plate.

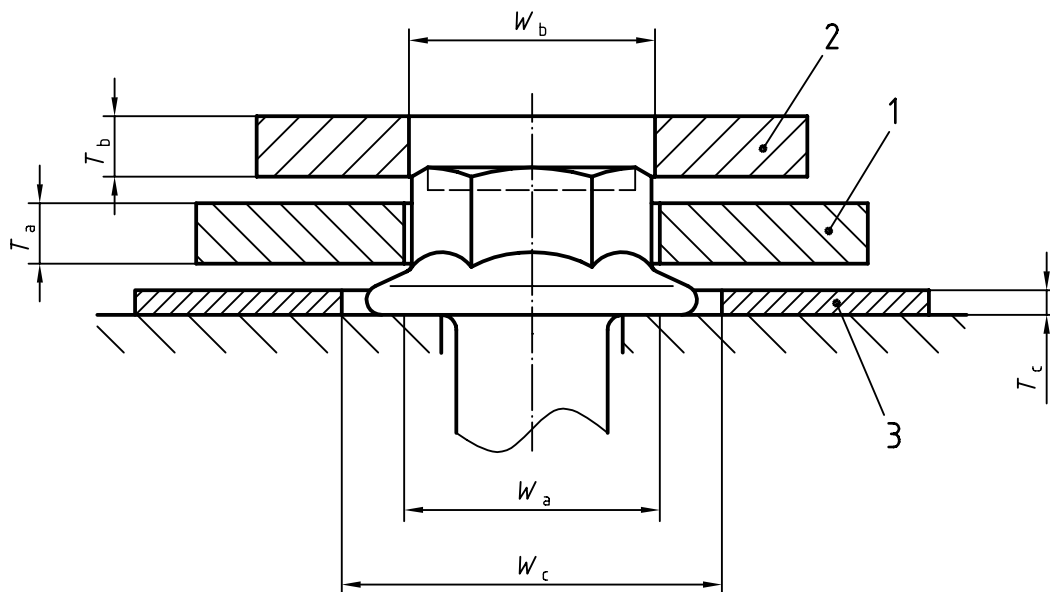

NOTE  $W_{a,min} = e_{theoretical}$   
 $W_{b,max} = e_{min} - 0,01 \text{ mm}$   
 $T_{a,max} = k_{w, min}$

#### Key

- 1 Gauge A
- 2 Gauge B
- 3 Gauge C

Figure A.1

**Table A.1**

Dimensions in millimetres

Nominal thread diameter ( <i>d</i> )	Gauge A				Gauge B			Gauge C			
	$W_a$		$T_a$		$W_b$		$T_b$	$W_c$	$T_c$		
	max.	min.	max.	min.	max.	min.	min.	max.	max.	min.	
<b>8</b>	11,56	11,55	3,80	3,79	10,94	10,93	4	20	1,31	1,30	
<b>10</b>	15,02	15,01	4,30	4,29	14,25	14,24	4	24	1,81	1,80	
<b>12</b>	17,33	17,32	5,40	5,39	17,61	17,60	5	29	2,20	2,19	
<b>14</b>	20,79	20,78	5,60	5,59	19,85	19,84	5	32,5	2,55	2,54	
<b>16</b>	24,26	24,25	6,80	6,79	23,14	23,13	6	37	2,96	2,95	

## Bibliography

- [1] ISO 888:1976, *Bolts, screws and studs — Nominal lengths, and thread lengths for general purpose bolts.*

---

---

**ICS 21.060.10**

Price based on 9 pages